

Operating Instructions

Tensile Testers

Z3, Z5, Z10, Z20, Z50, Z100

| | | |
|---|---|---|
|  |  |  |
| <p>Z3 Z5</p> | <p>Z10</p> | <p>Z20 Z50</p> |

5-2017

Table of Content

| | |
|-----|---|
| 1: | Introduction |
| 2: | Checking Contents and the Number of Machine |
| 3: | Power on checks |
| 4: | Control Display Unit |
| 5 | Menu Keypad |
| 6: | Configuration |
| 7: | Load Cell |
| 8: | Interface USB |
| 9 | Upload Hex file |
| 10 | Special Programs |
| 11: | Accessories, Maintenance |
| 12 | Windows-Software |
| 13 | Electric plan, Main board |
| 14 | Dimensions |
| 15 | Declaration of Conformity |

1) Introduction

Danger Hints

Warning Danger of crushing!

By the accessible design of the machine there is a risk of crushing

Please make sure that during the adjustment and during the test sequence no one comes to the area of the machine!

The device may only be operated by trained personnel.

Attention! The load cell can be destroyed by overload!

Especially upon moving the grips or by lateral load is the danger that the load cell will be destroyed.

Install load cells carefully.

There must be no larger torque pull off the grips pass through the load cell.

For smaller load cells, we recommend using pneumatic grips

Names

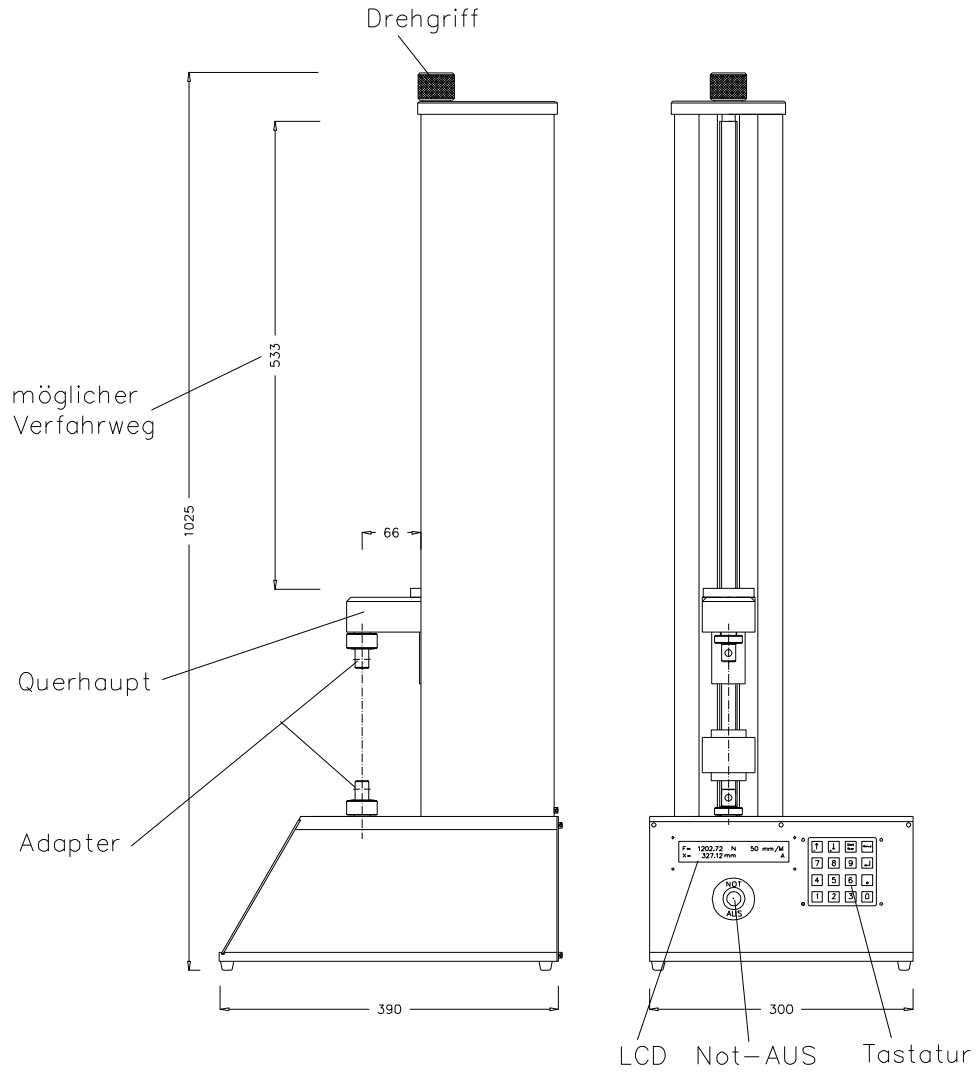

Kraft - Weg Diagramm

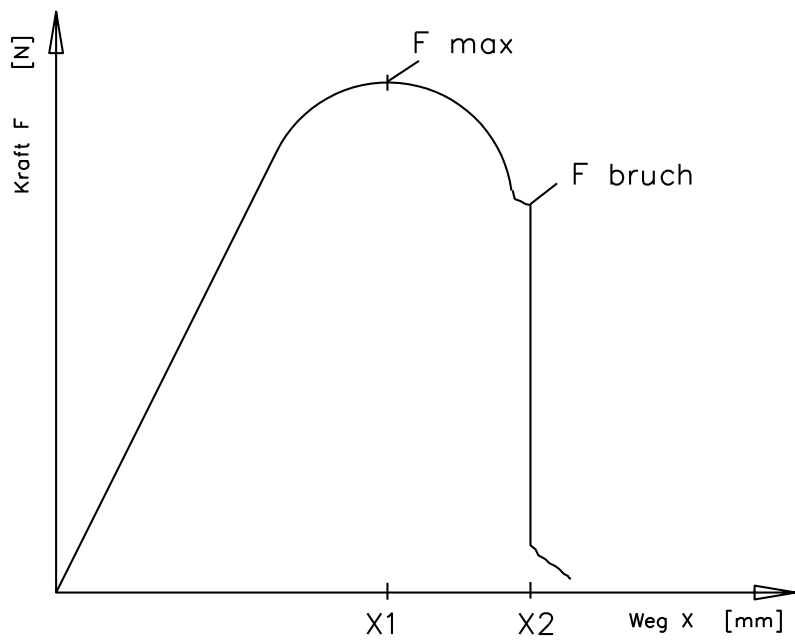

Notes

Limit

The limit switch must be set, so that the upper grip do not touch lower grip.

Transport

Disassemble load cell.

Z3 Z5 and Z10 machines are provided for voltages 230 VAC or 115 VAC See back side of machine

Machine Z20 Z50 Z100 needs 3x 380 Volt

We can decline down to 260 Volt; if it is lower we need a Trafo

1) INTRODUCTION

1.01 This manual is to help the operator understand the operation principle of the testing machine electronic panel.

These new testing machines represent a range of easy-to-use compact devices for determining Tension, Compression, Shear, Flexure and other mechanical and physical properties of materials. Due to variations in international standards of force and extension units, the tensile test machines enable the operator to select one of the two standards for Force Units (Newton and Pounds) and either Inches or Millimeters for the Extension Units.

1.02 All the controls are located on the front panel, which has a large, easy-to-read backlit 2-line LCD display and a numeric keypad. The display unit shows the force and displacement values. Crosshead control keys are provided for moving crosshead up or down, for starting a test, or for getting access to various test parameters, such as, for example, displacement or speed of crosshead. The numeric keypad permits the inputting of test data.

1.03 There may be many aspects of material testing not covered in this operation manual in particular the type of grips used and additional optional equipment (for more information see our webpage <http://www.grip.de/>)

Operating Environment – All machines are designed to operate in temperatures of 0 to 38°C (32 to 100°F) with a non-condensing atmosphere of 10 to 90% Relative Humidity.

2: CHECKING CONTENTS

The machines are shipped completely assembled except for the optional accessories. The basic machines are supplied with the following items (please insure that these are included for the installation):

- Z-Beam Load Cell at or below the maximum capacity of the load frame;
- Two Grip Pins (8 mm) for an adapter;
- operating instruction manual;
- load cell calibration certificate;
- One USB Serial Port Lead for external computer control;
- One 220 V cable.

The following diagrams are to help to identify each item:

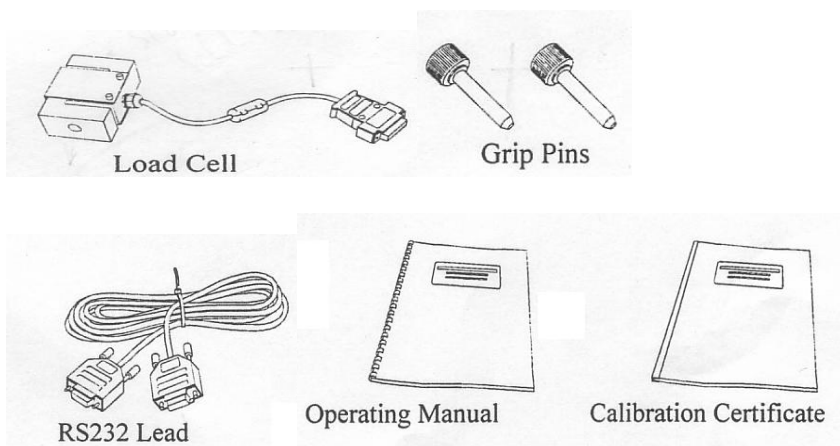

Type Number of Machine:

On the backside of each machine you will find a type number (Type Nr.). Please use it for future reference.

3) POWER ON CHECKS

Power On / Off Switch.

The On (1) and Off (0) power switch is located on the back side of the machine and should be in the Off (0) position before applying power to the machine.

The picture below indicates the location of the power switch:



1.3 Switching from 220 to 110 volts

Located on the back of the machine, Plug inside allows, that to switch to 110 Volt

Change 220Volt to 110Volt

How to switch power supply voltage to 110V

Tooling: You need a flat screwdriver.



Look at backside of your machine. Here is a Power Switch. It looks like this:



Voltage Mark indicates what voltage is selected. Here is 220-240V.
With screwdriver open fuse box:



Now rotate this, like it is shown on a picture below:

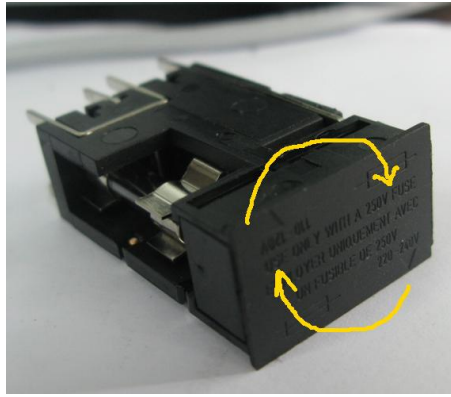

Now insert fuse box into switch. Also be attentive with voltage mark.



Now is selected to 110V. See Picture below. All done.

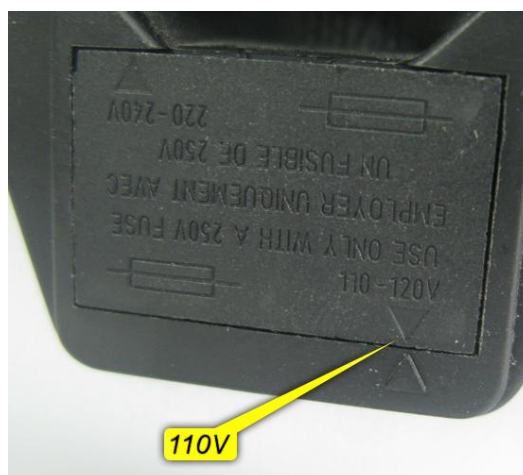

Emergency Stop Push-Button. The Emergency Stop push-button is located on the front panel of the machine.

To activate the emergency stop you have to push the button. To deactivate the emergency stop turn the button to the left and the button jumps out.

The picture below indicates the location of the emergency stop push-button:



Mechanical Limit Switches.

Before attempting to move the crosshead in either direction it will be required to set the mechanical crosshead limit switches. The purpose of the limit switches is to reduce the travel of the crosshead enabling a safe working area. A typical example is to protect the load cell and attachments for unforeseen over travel and in doing so avoid a collision. These limit switches are located on the left hand side of the machine.

The figure below shows the location of the mechanical crosshead limit switches:



The limit switches are held in position by a locking screw. To set the limit switch, unlock it by turning the locking screw in the counterclockwise direction and slide to the required new position. To lock the limit switch, rotate the locking screw in the clockwise direction. (Note: To eliminate slippage, re-tighten locking screw securely).

The diagrams below indicate mechanical crosshead limit switches:

Release Upper Limit Switch, move crosshead to a new position, slide limit switch to crosshead striker, Re-tighten.

Release Lower Limit Switch, move crosshead to a new position, slide limit switch to crosshead striker, Re-tighten.

4) DISPLAY UNIT

Control Display Panel. This unit contains the LCD Display, the Numeric Keypad and the Emergency Stop push-button.



LCD DISPLAY

When you switch on the machine, you get a message about the Firmware. You will see the following:

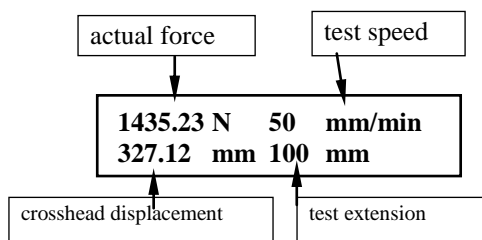

When the test is finished (i.e. when the extension is reached, or the maximum force is exceeded, or the break of the specimen is detected), you see the maximum force of the last test.

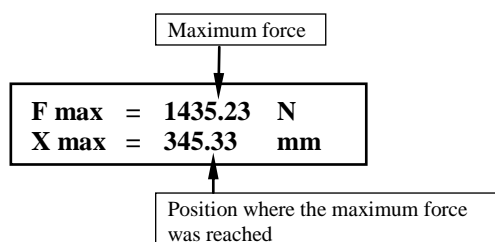

By pressing the [2] key the operator gets the information about the force at break.

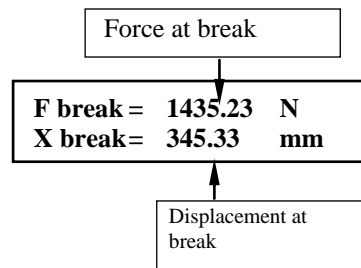

5) Menu Keypad

Numeric Keypad: These keys are used for entering numeric values on the LCD-Display (Speeds, Extension, etc.).

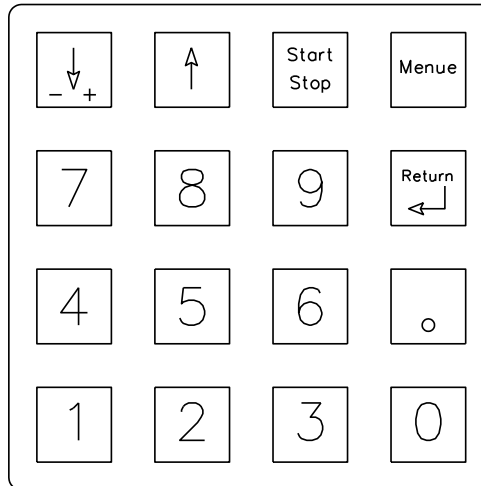

Crosshead Control Keys: There are two crosshead directional arrows:



The down arrow is used for lowering the crosshead and for inputting negative values.



The Up arrow is used for raising the crosshead.



This key starts and stops a running test. If the [Start – Stop] key is pressed during a test, the procedure is interrupted. The same happens if you press any other key.



With the menu key, the operator can make settings for the next test. The adjusted settings should be confirmed with the Return key.



By pressing the [Return] key, the operator stops or returns the crosshead to zero extension after the test.



This key will zero the Force and Extension display.

- 1** This key shows the maximum Force and the referring Extension of the last test.
- 2** This key shows the Force and the Extension of the Rupture.
- 3** This key has no function.
- 4** This key has no function.
- 5** This key is used to enter the configuration menu. This menu is protected with the password (09122).
- 6** This key has no function.
- 7** This key has no function.
- 8** This key allows switching to constant force mode.
- 9** This key has no function.

MENU

M

The [Menu] Key

With this key the operator can make settings for the next test. The adjusted settings should be confirmed with the [Return] key.

If you press the [Menu] key, you will see the following:

ENDPOS - means "Test Extension".

The range is possible from 1 mm to 540 mm (for the smallest version of the machine), except for the length of grips and a specimen. Positive values mean tensile test; negative values mean compression test. In order to change from "–" to "+" you have to press the [Down] key.

V means "Test Speed".

The range is from 0,5 mm/Min to 500 mm/Min (only positive values are possible).

F-LIMITS - means "Force Limit".

The Force Limit can be used to protect tooling rated lower than the load cell capacity, to end a test when that force is reached.

F-DELTA - means Force Delta.

Force Delta is the sensitivity for detecting the rupture of a specimen, i.e. the value of 200N means, if during a tensile mode the load decreases more than 200N/50ms, the rupture is detected and the test is finished.

If the value is too low, rupture is not detected by the machine and runs till the end of the set movement

Breaking force, the next interesting force after the maximum force it is difficult to recognize for the small machine

*Therefore, we recommend to setting F-delta to 5% of the maximum force
The expected minimum decline of load within 1/50 second after rupture.
(Between 2 measurement points we measured 50 times per second)*

If F-delta is set correctly, the machine stand and the value is displayed

If it too large set the machine drives until the maximum test length is achieved

If it is too small set, the tensile strength will be detected too early - ie. The machine stops although the candidate has not yet been reached

F-MAN - means Jog Speed.

The range is possible from 1 mm/Min to 500 mm/Min.

6: CONFIGURATION

Change of Configuration

By pressing "Menu" during power on or "5" key you activate the Configuration menu.

To prevent accidental change of configuration it protected by a code

Proceed as follows:

*After pressing "5" key, the display shows: "Paßwort?"
Now type: "09122". If you entered the code correctly,
You can either load the pre-set values or change them.
Display shows: "Grundeinstellung ?"
"Ja"=0*

*By pressing "0" the machine loads the following values:
By pressing "Return" you skip the defaults.*

Defaults values:

Language (Sprache)

1=Dutch, 2= English, 3= Italian, 4= French.

UNITS 1/2 mm N / in lbf (1lbf = 4.44822 N / 1 in = 25.4 mm)

| | | |
|---|--------------|------------------|
| <i>LOADCELL</i> | <i>[N]</i> | <i>2000</i> |
| <i>Load cell Sensitivity ("Lastzellenempfindlichkeit") [mV/V]</i> | <i>3.165</i> | <i>(example)</i> |
| <i>Calibration factor ("Kalibrierfaktor")</i> | <i>[FAK]</i> | <i>1.000</i> |

By pressing "0" you start a Calibration program

| | | |
|--|-------------|------------------|
| <i>F limit H (maximum force for Hardware)</i> | <i>[N]</i> | <i>1500 [N]</i> |
| <i>repositioning speed („Rücklaufgeschwindigkeit“)</i> | <i>[VR]</i> | <i>500mm/min</i> |

F (0) [N] (preload)

These settings are stored in a non volatile ROM and are re-established after every power on.

We recommend, noting all changes on a book.

Machine type

'Machine type' can be set, from 1 to 6 values, with following meaning:

| | | | |
|-----|---------------|---------------------|-----------|
| '1' | DC-Servo 40W | 500mm | Z3-X500 |
| '2' | DC-Servo 40W | 1200 mm | Z3-X1200 |
| '3' | DC-Servo 80W | 500mm | Z5-X500 |
| '4' | DC-Servo 80W | 1200 mm travel | Z5-X1200 |
| '5' | AC Servo 300W | 10 KN 700mm travel | Z10-X700 |
| '6' | AC Servo 300W | 10 KN 1200mm travel | Z10-X1200 |

In machine without program (empty) this parameter is automatic set to '1'.

For more information see info-hex-3-65.txt file.

By pressing the [M] key during the switching on the machine until the “Password” is shown on the Display, or by pressing the [5] key the operator enters the configuration menu. To prevent an accidental change of configuration data, this menu is protected with the password.

The procedure is as follows:

By pressing the [5] key the display shows “Password?” the operator should press “09122” and after that the settings of the machine can be changed.

Language Selection:

| | |
|------------------|----------|
| LANGUAGE: | 1 |
| German =1 | ↑↓ |

With these keys the operator can choose the desired language and with the [Return] key confirm the choice.

The operator can also select the desired language:

- 1** =German
- 2** =English
- 3** =Italian
- 4** =French
- 5** =Spanish
- 6** =Danish

(Add a new language

<http://www.youtube.com/watch?v=LDNiQRc5TIQ&feature=youtu.be>)

The Selection of The Used Units:

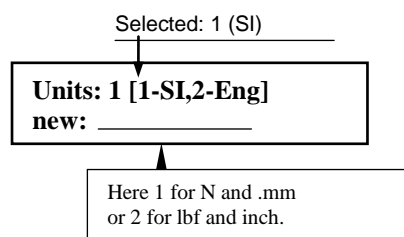

If you use the system “Millimeters/Newton (mm/N), you have to press [1]; if you use the system “Inches/Pounds (in/lbf), press [2].

By pressing the [Return] key you go to the next Menu-Entry.

6.03 Load Cell Capacity:

| |
|---------------------|
| Load cell 2000 N is |
|---------------------|

| |
|--|
| ↑ Here enter the changed value and Confirm with the [Return] key |
|--|

Load Cell Sensitivity:

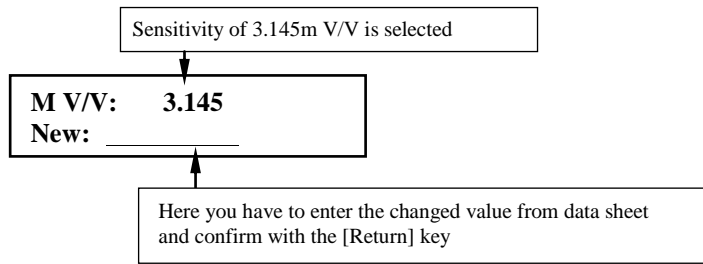

Calibration Factor:

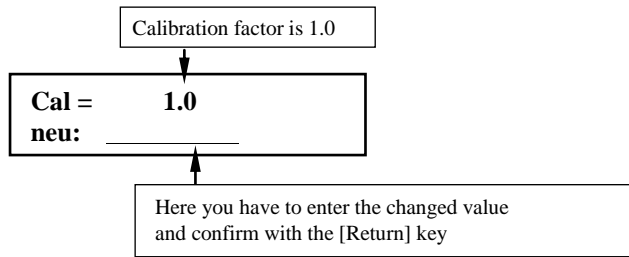

If you enter [0]", you start a calibration program (see: "Change of the load cell").

Maximum Force of the Machine:

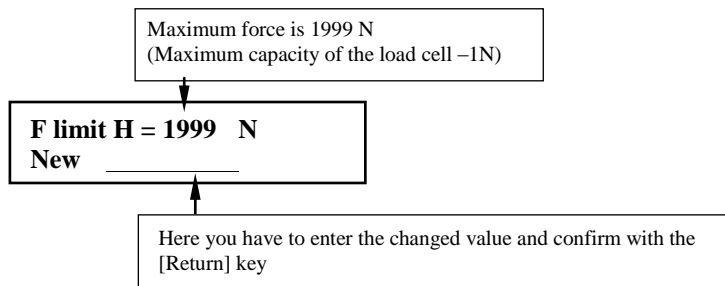

When the amount of the force is exceeded, the machine is automatically switched off and an emergency message is shown.

Return Speed: Return Speed is the speed for the Return key ("Return home function").

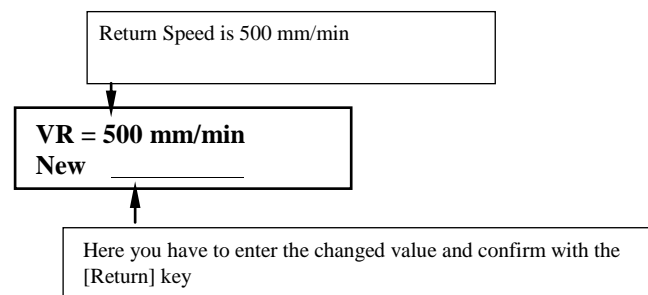

Digits After The Decimal Point:

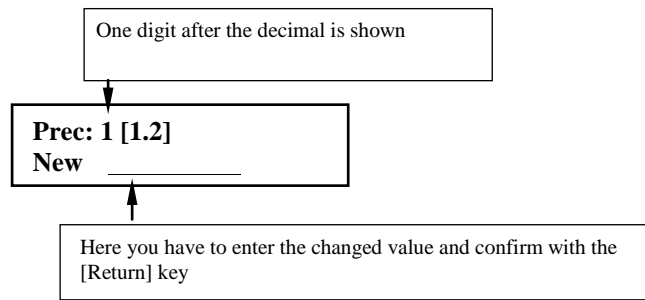

“Prec” means “Precision.

Type of the Machine:

The “Machine type” can be set from 1 to 6 with the following meaning:

- 1 for TH 2730 3 kN (40 W, 500mm);
- 2 for TH 2730 3 kN (40 W, up to 1200 mm (a long version));
- 3 for TH 2730 5kN (80 W, 500 mm);
- 4 for TH 2730 5 kN (80 W, up to 1200 mm (a long version));
- 5 for TH 3630 10 kN (2x80 W, 500 mm);
- 6 for TH 3630-1000 10 kN (2x80, up to 1200 mm (a long version)).

6.10 Perforce setting:

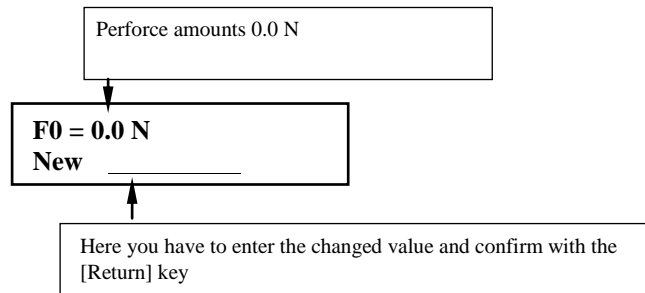

If the actual force exceeds the perforce during the tensile test, or drops below the perforce during the compression test, the extension measurement begins with 0.00 mm. This function is ineffective when the perforce amounts 0 N. All settings are power-failure safe stored.

Perforce Function

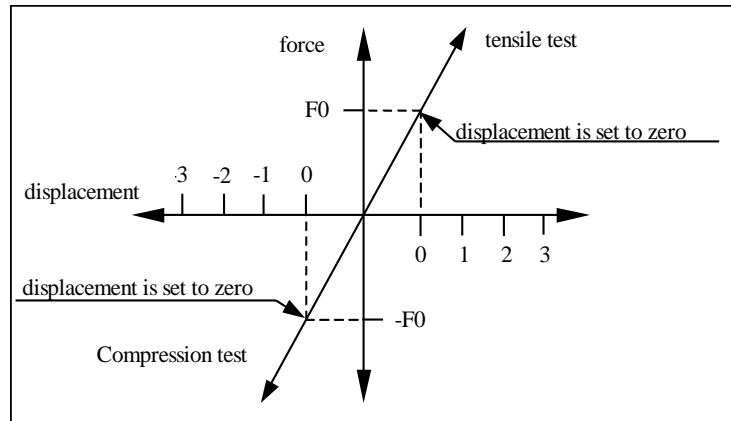

7) LOAD CELL

Limits of the Load Cell

The Load Cell may not be deformed more than max. 0.2 mm in pulling direction!

Doing pressure tests, ensure that the Load Cell does not bend out to the side!

Low force Load Cells: There is a high risk of damage by permanent bending, which is due to the Load Cells construction principle.

In case there is a danger of Load Cell Overload, we recommend using special protection equipment.

In any case we propose pneumatic grips for small load cells to avoid over bending by manual closing grips.

After overload damage, the Load Cell may still show measurements, but is not linear anymore.

To ensure the accuracy of a Load Cell a calibration test should be done with multiple different weights.

If necessary adjust the calibration factor.

We only can provide the Load Cell Function as guaranteed by the manufacturer.

Any warranty claims which are due to male operation or overload will not be accepted.

Zero adjustment

By pressing "0" before testing a **Zero adjustment is done.**

As the clamping of probes does already produce forces, a **Zero adjustment** should be always done before testing.

Change of load cells

In order to change the load cell you have to do the following:

Switch off power on the machine

-
- loosen the screw at the cross bar
- mount new load cell with the screw at the cross bar
- put load cell plug into the connector at the back side of the machine
- Switch on the machine again and wait to the end of the self-test procedure
- press "5"
- type Password: "09122"
- save old parameters on a piece of paper and type the new values
 - set new parameter for 'Load cell' e.g.: 2000 [N]
 - set new parameter for 'mV/V'
(load cell sensitivity) e.g.: 3.165 [mV/N]
 - set new parameter for 'Cal' (calibration factor) to "1"

Set calibration factor with weight

Put a calibration weight at the load cell, e.g. 10 kg = 98.0665 N (**

The display should show a similar value

E.g. the display shows 95.6 N the calibration factor must be increased:

From 1 to 1.03745 (use calculator)

Check the changes with the weight again!

** (this is dependent to your location and valid for 45° northern /
e.g. north pole 98.32 N / at the Equator 97.80 N

Mounting procedure of Load Cell

Caution!

Small type of load cells can easily be deformed especially by torsion forces.

Never put torsion forces on the Load cell while tightening or loosening probes and clamps

Only hold the load cell at the upper part! -----
Right ↓

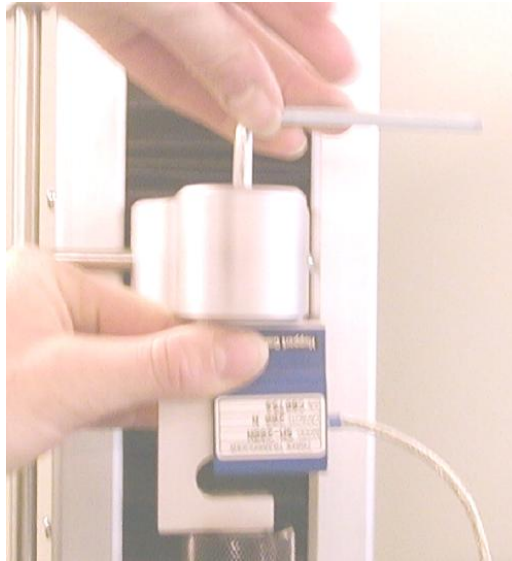

✓ OK.

Wrong ↓
Do not mount like this! Load cell is likely to be destroyed.

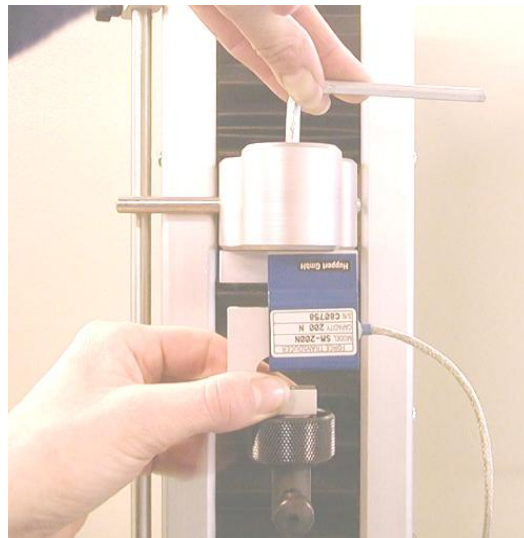

✗ never

Load cell have a fragile area with tiny parts and adjusted DMS strips inside.
These thin strips can easily be deformed permanently by torsion forces.

Fitting Load Cell:

The Z-Beam type load cell is mounted under the moving crosshead. Your machine will be provided with a load cell equal to or less than the maximum capacity of the machine. Connect the load cell by plugging the 5 pin connector into the load cell socket on the rear side of the machine.

Limits of the Load Cell:

Load Cell should not be deformed more than maximum 0.2 mm in both directions.

When doing pressure tests, be sure that you do not bend a load cell to the side. Using a low force load cell, there is a high risk of its damage by permanent bending of the load cell which is due to its constructive principle. If there is danger of the load cell overload, we recommend using special protection equipment which we also provide

After overload, the load cell still shows measurements but they are not linear anymore.

That is why we recommend using pneumatic grips for low force tests to avoid an accidental destruction of the load cell when tightening the clamps.

To ensure the accuracy of the load cell, a calibration test should be done with different weights.

If it is necessary, adjust also the calibration factor.

We can only provide the load cell function as guaranteed by the manufacture. Any claims which are due to false fixing or overload are not accepted.

Zero Adjustment:

By pressing the [1] key before testing zero adjustment is done.

As the clamping of a specimen already produces force zero, adjustment should be always done before each test.

Calibration with a Weight:

In order to increase the accuracy of the machine you have to calibrate with a known weight.

It is done as follows:

- remove load from the load cell (if there is any);
- set calibration factor to "0".

The display shows now:

(Do not be confused that the display shows the messages in German - this program is used seldom, that is why we did not translate it into English. On the right side of the page you see the messages translated into English).

mit Gewicht eichen
weight calibr. 1=ok

Calibrate with weight
Weight calibre 1=ok

Confirm with the [1] key, then you see:

Lastzelle entlasten
weiter mit Taste

Remove load from the load
cell

Please care that there is no vibration - then press any key.

Last aufbringen
weiter mit Taste

Burden the load

Now hang a known weight on the load cell, wait and then press any key.

Faktor bestimmen
weiter mit Taste

The machine calculates the
factor

Press any key.

Faktor bestimmen
15%

The machine calculates the
factor 15%

The machine calculates now the factor automatically, it counts from 1 till 100%. When the procedure is completed, the machine expects that the operator enters the force that the load cell was loaded with.

Last: 38.460 N
Neu:

The pre-set force is 38.460
N
Enter the loaded force

Now you have to enter the force that the load cell was loaded with.

38.46 N
Last ok=1 again=9

The actual force is 38.46 N
Force ok =1 again=9

Because of the vibrations of the machine the last digit of the force reading is not stable.

The average value should be the same as the weight. When you are satisfied with the calibration, press the [1] key and you will end the routine. If you press the [9] key, you start the procedure once again.

The display shows the calculated calibration factor.

Faktor ist gesetzt:
1.003

The factor is set:
1.003





Video

http://youtu.be/Kpsg_-LxmYM

calibrate with a weight

Multi Load cell system

In case of usage of several load cells we recommend to activate the Multi load cell Routine

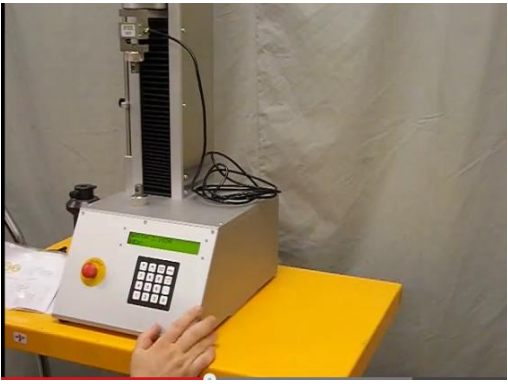
| | |
|---|---|
|  | <p>activate Multi load cell Routine</p> <p>http://youtu.be/QTWwEAASxMQ</p> |
|  | <p>change of load cell with the Multi load cell Routine</p> <p>http://youtu.be/UP3VIIoy_mo with subiteles</p> <p>http://youtu.be/BRnBhRSHG2w</p> |
|  | <p>change load cell calibrate a second load cell with Auto calibrating</p> <p>http://youtu.be/4nMdiXiluKI with subtitles</p> <p>http://youtu.be/y_sCxeLPJkM</p> |
|  | <p>change load cell, calibrate and set load cell number in Multi calibration Routine</p> <p>http://youtu.be/fy9mkMBP9DM</p> |

8) **INTERFACE USB**

USB VCP communication for the family Z3-Z100 machines

The family of Z3-Z100 machines (3, 5, 10, 290, 50; 100 kN) can communicate with a PC via USB Virtual Com Port. Speed of communication is fixed at 1562500 bps and can't be change by user. For connection, between the PC and the machine is used the standard USB A-B cable. Cable should be not longer than 10 m.

| Serial communication port | |
|----------------------------------|--------------|
| Parameter | value |
| Baud rate | 1562500 bps |
| Data | 8 bit |
| Parity | None |
| Stop bits | 1 |
| Protocol | None |

General syntax of commands

All orders are created from **UPPER CASE** character (or two) in **ASCII** format, optional parameter value with sign (if negative), **point** as decimal separator (if present) and dollar (\$) sign on end of each command.

Example of single order (new 'Endpos' value)

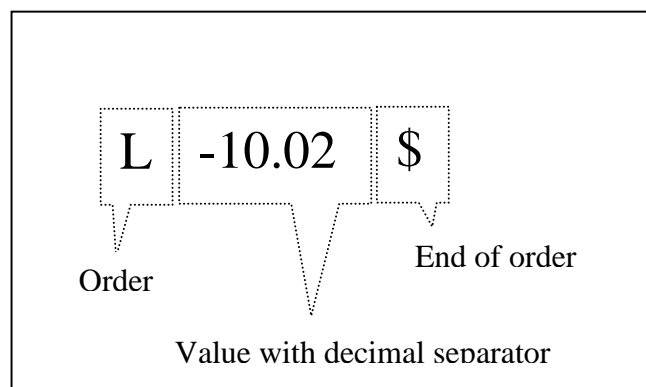

* Between order character value and "end of order" mark is no space.

Table of orders

| Order | Function | Example/ Syntax | Result |
|----------|---|--------------------|--|
| | End of command is \$ or #10 | | * Decimal separator is always '.' (point) |
| 'A' | Actual readings | A\$ | Force ; Way; Way (from extensometer or LVDT or MFE900 only when is enabled) |
| 'B' | Last readings (rupt. value) | B\$ | F rupt X rupt |
| 'D xxx' | Set F delta | D20\$ | F delta=20N |
| 'DA xxx' | Ask for "Auto delta + 20%" | DA\$ | Return Auto delta=21N |
| 'E' | Return to zero position (if Ref mode >0 Return to "Start pos"). | E\$ | Return button (to 0,00mm) |
| 'F xxx' | Set limit of force in test (F limit S) | F200\$ | F limit S=200N |
| 'H' | Stop machine (or break CFR) | H\$ | Stop button |
| 'I?' | Ask for Way display mode (if Extensometer or LVDT or MFE900 is enabled) | I? \$ | "I:0" – standard Way display "I:1" – Way from Extensometer on LCD "I:3" – Way from LVDT on LCD "I:4" – Way from MFE900 on LCD |
| 'Ix y' | Set Way display mode and L0 value (if Extensometer or LVDT or MFE900 is enabled). | I1 25.00\$ | Way from Extensometer on LCD and L0=25.00 mm |
| 'J xxx' | Set return speed | J200\$ | VR=200 mm/min |
| 'K0' | Set normal mode | K0\$ | Machine in Normal mode |
| 'K1' | Set Constant Force Regulation mode | K1\$ | Machine in CFR mode |
| 'K?' | Ask for status Constant Force Regulation mode (active or not) | K? \$ | "K1\$" - Machine in CFR mode "K0\$" - Machine not in CFR mode |
| 'L xxx' | Set end position for test | L100\$ | X=100mm |
| 'M' | Last readings (max. value) | M\$ | F max X max |
| 'N' | Read nominal load | N\$ | 2000 (Load cell = 2000N) |
| 'O' | Reset Load cell and position counter | O\$ | 0,0N 0,00mm |
| 'O1' | Reset position counter only | O1\$ | 2,0N 0,00mm |
| 'O2' | Reset Force only | O2\$ | 0,0N 7,34mm |
| 'O3' | Reset Time Stamp (option) | O3\$ | |
| 'O4' | Reset LVDT (when LVDT enabled) | O4\$ | |
| 'O5' | Reset MFE900 counters (when MFE900 enabled) | O5\$ | |
| 'OR' | Reset Reference offset (when Ref mode >0) | OR\$ | 0,0N 7,34mm |
| 'P xxx' | Set pre-force (F0) | P0.4\$ * | F0=0.4N |
| 'PP xxx' | Set pre-force for perforce speed (in not the same as 'F0'). | PP0.4\$ * | Pre-force=0.4N |
| 'Q xxx' | Set constant force to keep (in CFM) | Q200\$ | Force to keep = 200N |
| 'QH xx' | Set the stiffness factor for CFR Where 0 <= xx <= 10 | QH5\$ | Stiffness=5 (min 0, max 10) |
| 'QT xxx' | Time of Constant Force Regulation (1-604800 sec) | QT3600\$ | After 1 hour End of CFR |
| 'R' | Begin of test (start the test) | R\$ | As 'START' button |
| 'RS' | Begin of silent test (start the test) | RS\$ | This test sent no data, host can ask |

| | | | |
|--|---|------------|---|
| | | | for data. |
| 'RH x y' | Begin of hysteresis test where: x- delay time [sec] before return, y-n times repeat ('0' for only cycle, '1' for two, ect. | RH0 0\$ | Start driving to 'Endpos' or 'F limit S' and after delay time 'x' drive back to the start pos. and repeat 'y' times. |
| 'RESET0' | Hard reset | RESET0\$ | Reset of system (Reboot) |
| 'RESET1' | Reboot & start SCIA bootloader | RESET1\$ | Reboot in "update mode" |
| 'S' | Ask for Status | S\$ | Condition of machine Bit #0 fast (jog keys active) running ; (test is running) schleppf ; (motor contouring error kraftmode ; (CFR active) ref_sw ; (option) endsw_dn ; endsw_up ; overload ; (load cell overload) Up Dir ; (driving up) Motor -Error; (servo off-line) OTW- Warning; Door- open; (option) Bit #12 Reference; |
| 'SER?' | Ask for user serial number | SER? \$ | "1234" |
| 'SER: xxx' | Set user serial number (max 20 char, can be used to keep machine ID) | SER:1234\$ | "1234" |
| 'T' | Ask for software version no. | T\$ | "Z 5.05 07.2012" |
| 'U' | Ask for active units (1-SI, 2-US) | U\$ | "1" |
| 'V xxx' | Set speed testing speed | V100\$ | V=100mm/min |
| 'VP xxx' | Set perforce speed (used when ' Perforce speed' enabled in service menu. | VP10\$ | V pref=10mm/min |
| 'X xxx' | Move to position (no position info) | X20\$ | Absolute, 20mm |
| 'XA xxx' | Move to absolute position (with pos info) | XA20\$ | Absolute, 20mm |
| 'XR xxx' | Move to relative position (with pos info) | XR20\$ | Relative, 20mm to up from actual position. |
| 'W xxx' | Set 'Start Position' used when Ref mode >0 | W50\$ | Machine after "Return" order drive back to 50mm (not to "0") if Ref mode >0 |
| Special commands to reload configuration data of the load cell ¹⁾ | | | |
| 'CN xxx' | Set "nominal value" of the Load Cell | CN2000\$ | Nennlast = 2000N |
| 'CE xxx' | Set "mV/V" value of the Load Cell | CE3.023\$ | mV/V = 3.023 |
| 'CK xxx' | Set calibration factor of the Load Cell | CK0.998\$ | Cal = 0.998 |
| 'CG xxx' | Set F limit F value of the Load Cell | CG1990\$ | F limit F = 1990N |
| 'CP xxx' | Set display precision (1 or 2) | CP2\$ | Prec = 2 (2 places after decimal point of force values). |
| 'CD xxx' | Set DIGITS value for motor encoder | CD10512\$ | DIGITS = 10512 (pulses/mm) (for BLDC motor is 6080 p/mm) |
| ¹⁾ When command C? xxx is send without parameter (i.e.: CN\$) then you get back actual parameter. | | | |

9) Upload Hexfile

The Hex Program in the single board computer can be changed (updated).

For this, the program serves "Loader.exe" and the file hex "

However, please observe the setting values of the tensile testing machine for safety, Note before!

After the loader is started, select port number then select the hex file.

The machine must be switched on, may not run in a test
the loader transfers the hex file to the machine and starts the program.

The current manuals and the latest software packages, see

<http://www.grip-soft.de/>

Questions or problems with the software, please send e-mail to

service@grip-soft.de

10) **Special Programs**

F (0) Mode

*If F (0) Mode is set to "1" x will automatically be set to 0
If load will come to a special value (after touching the sample)
Used for compression tests*

Constant Force Regulation

With key "8" you can switch to force regulation

With key "Menu" you can set force

*For example, 5 N makes tension 5 N
For example, 5 N makes compression 5 N*

*If you press "Start" key, force regulation will be activated
machine drives slowly to this force*

*If you press again on key "8", you will come back to normal
constant speed regulation*

*in constant force regulation modus you can change settings
depending on hardness of material from 1 to 10*

Push button Menu of tensile tester

*if material is weak push 1 reaction speed is high
if material is hard push 10 reaction speed is low*

11) Accessories, Maintenance

*1 USB cable
1 110/220V cable
2 pins 8 mm for adapter
1 certification of load cell*

Grips see also <http://www.grip.de>

Maintenance

Keep all parts clean. Work with vacuum cleaner not with compressed air.

Grease: We propose grease for bearings and ball screw Klüber ISOX NBU 15 (all 300 hours of active usage – ball bearing has a greasing possibility in the centre of machine remove cap in center of protection sheet) do not use oil

12) **Windows software**

You can download actual software, manual and hex file from our software homepage

<http://www.grip-soft.de>

see also <http://www.gripsoft.de/THSSD/THSSD.html>

Software installation:

1. Download software here http://gripsoft.de/current/USB/THSSD_R1_USB.zip
2. Download USB FTDI chip driver here <http://www.ftdichip.com/Drivers/CDM/CDM%20v2.12.00%20WHQL%20Certified.exe>
3. Install USB driver
4. Unpack software
5. Connect and power on ZPM machine
6. Run software (executable file). Software is portable.

Online help you can find here <http://gripsoft.de/THSSD/THSSD.html>

Software was tested with:

- Windows XP SP3 x32
- Vista business x32 SP2
- Windows 8 x64
- Windows x32-x64,
- Windows 10 x32-x64.

Hardware Requirements:

1. USB 2.0 communication port.
2. CPU: Dual Core 1.6 GHz or higher
3. RAM: 2 GB or higher
4. 1024x768 screen resolution or higher
5. Mouse or touch-pad (notebooks)
6. Keyboard

Software Requirements:

1. Operating system: Win XP (32-bit version only), Vista, Win 7, Win 8, Win 10

13) Electric Plan

by pulling give positive value (Nordic/Huppert/Interface)
Load Cell 50N - 5000N

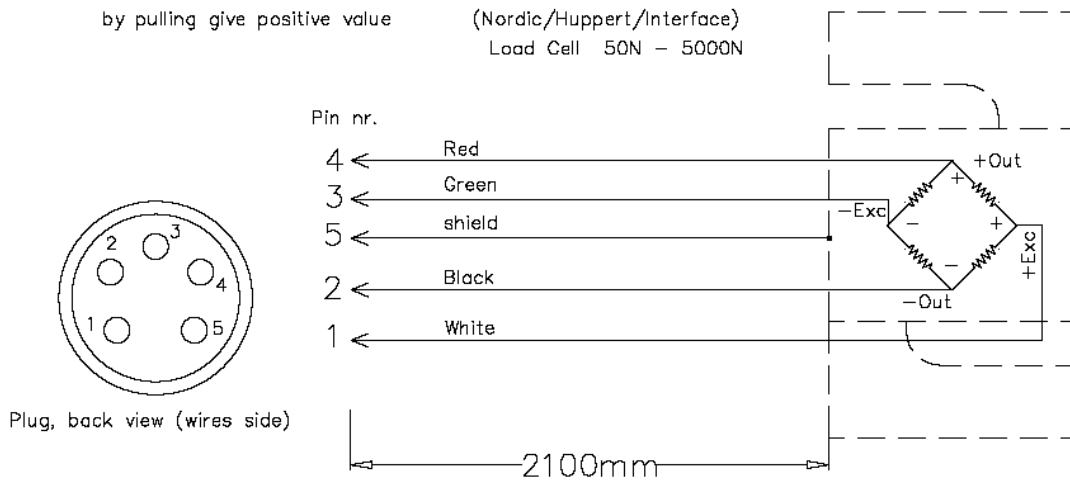

Main Board

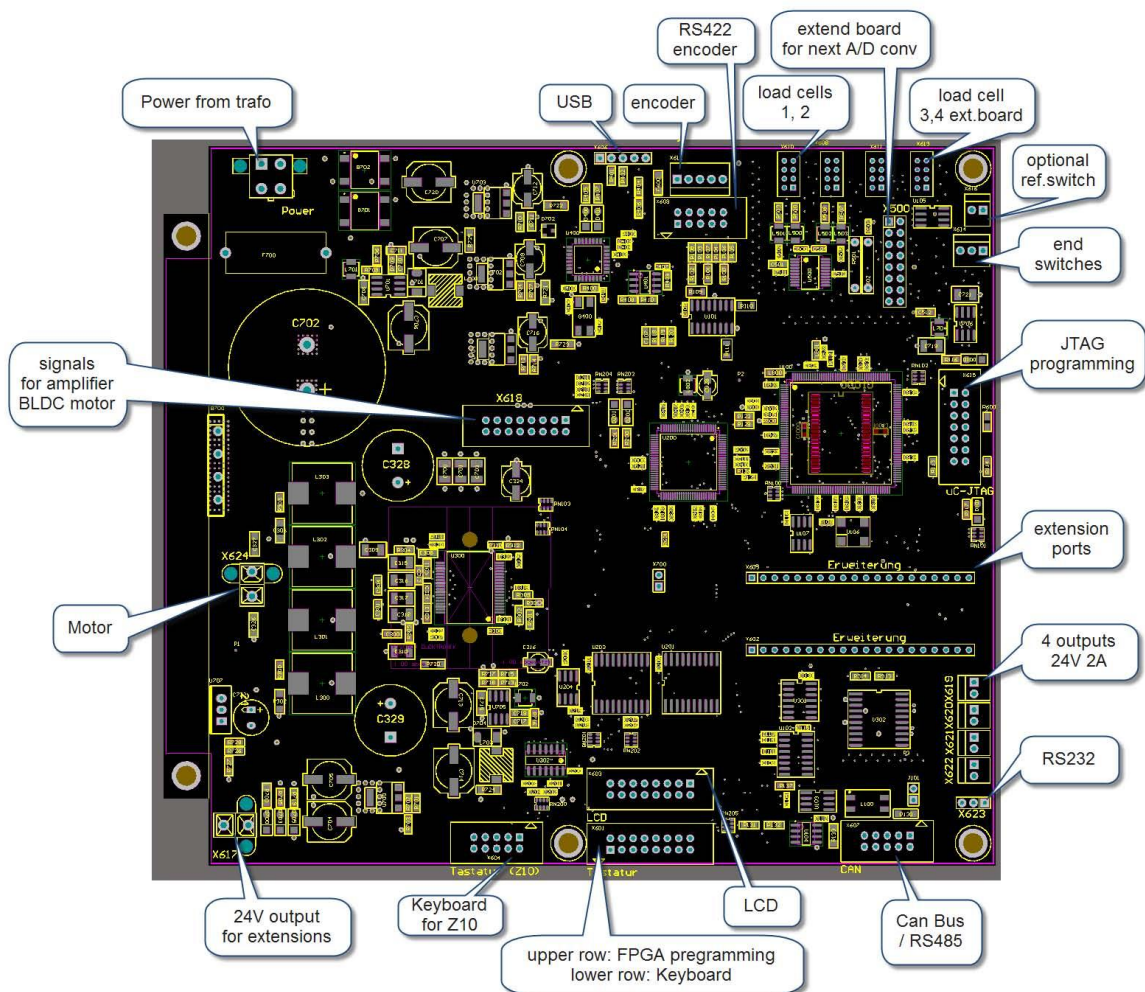

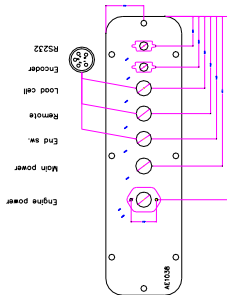
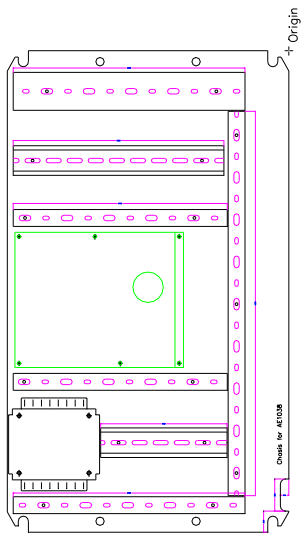
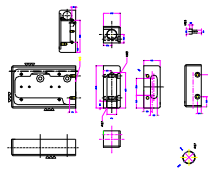
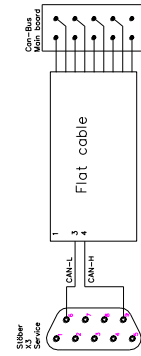
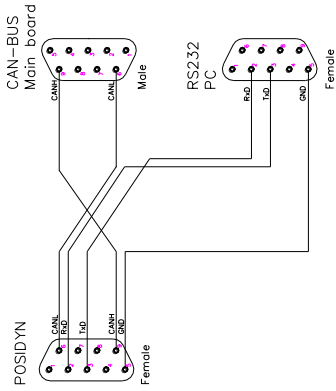
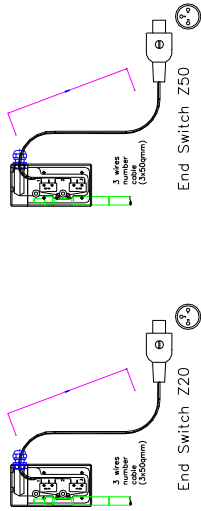
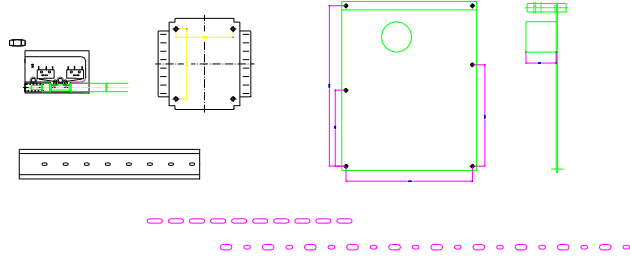

Remote control

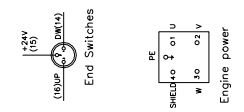
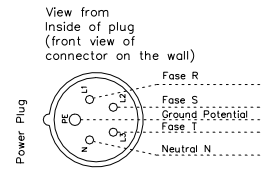
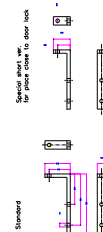
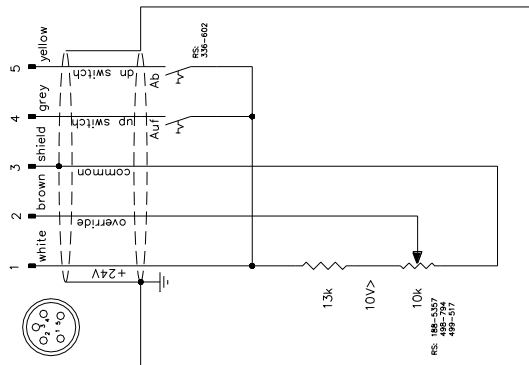

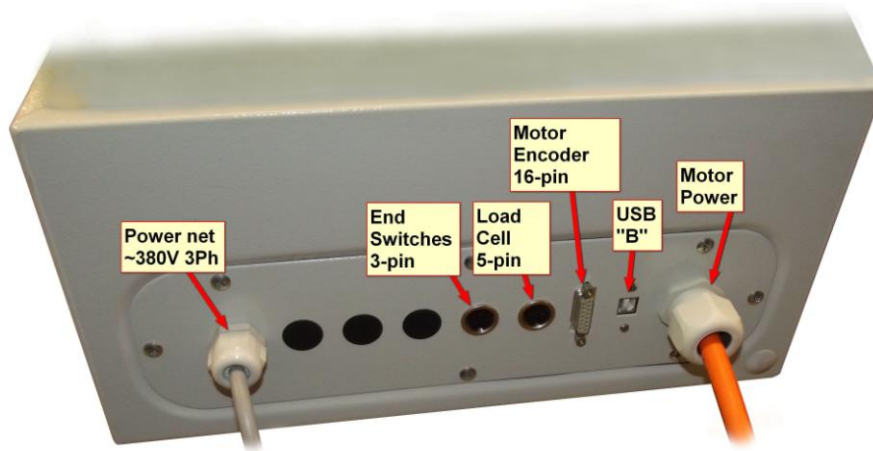

Z20 Z50 Z100 only lower view of electric box

14) Dimensions

Adapter Z3 and Z10

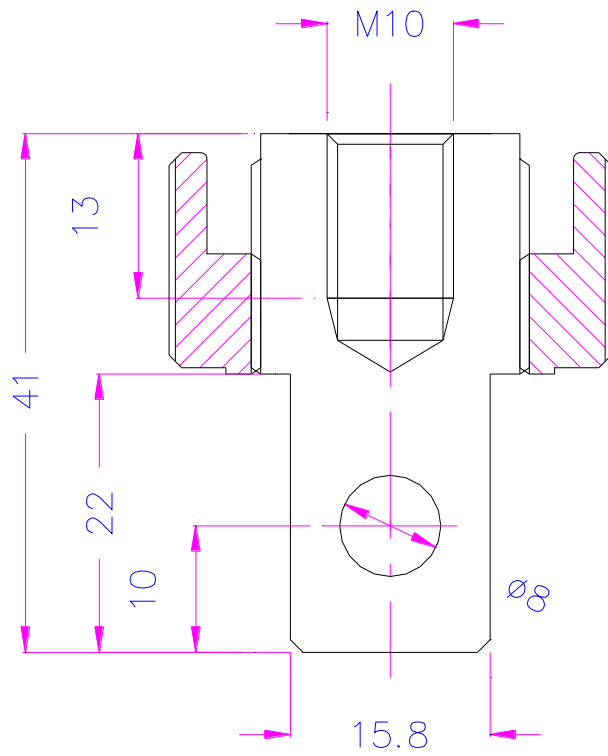

THS438-15.8-M10

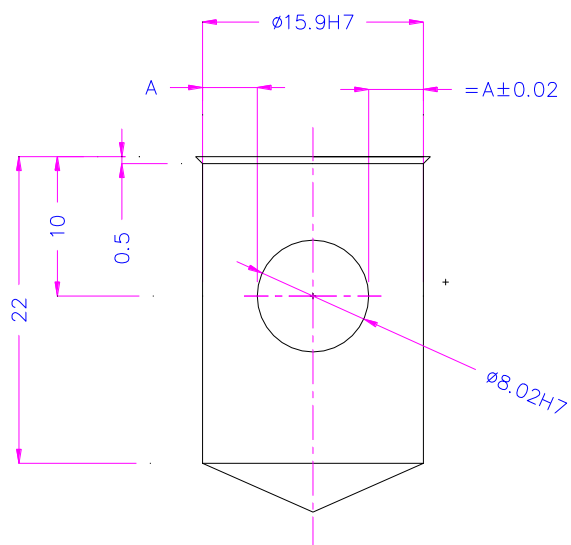

Adapter size: Z20, Z30, Z50.

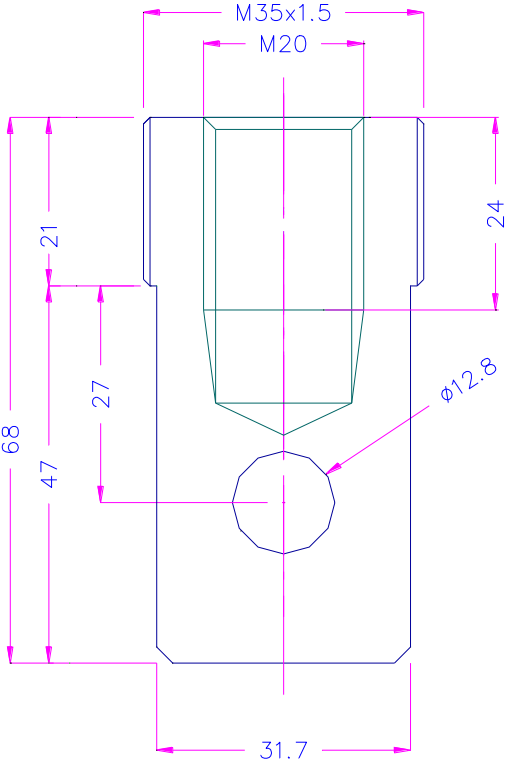

THS438-317-M20

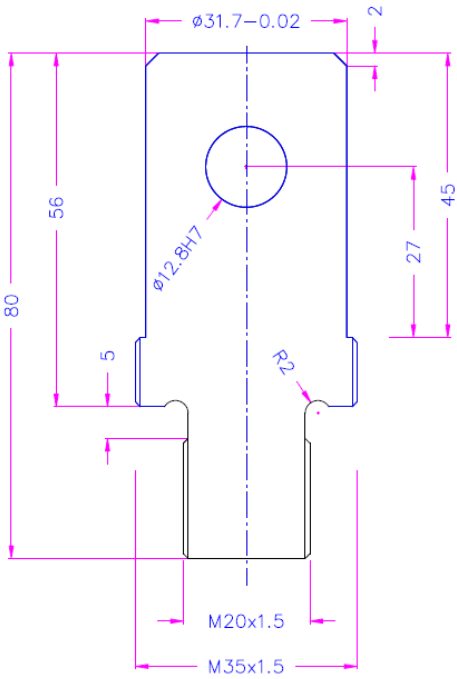

Z20-59-A317o

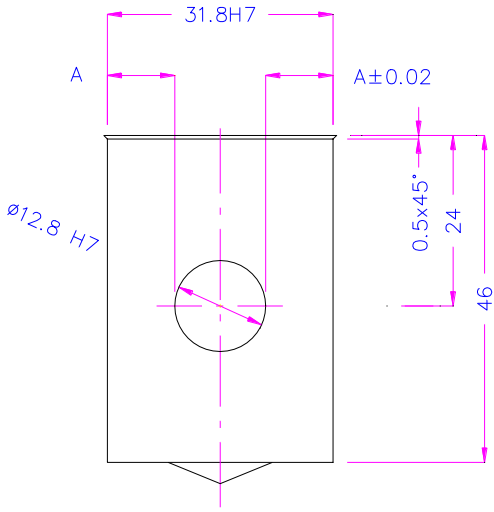

Af318

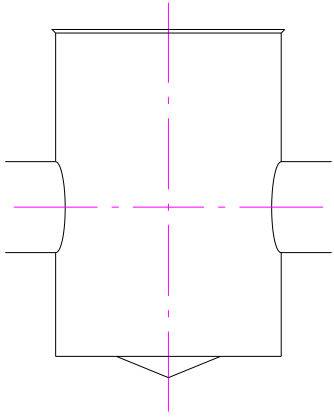

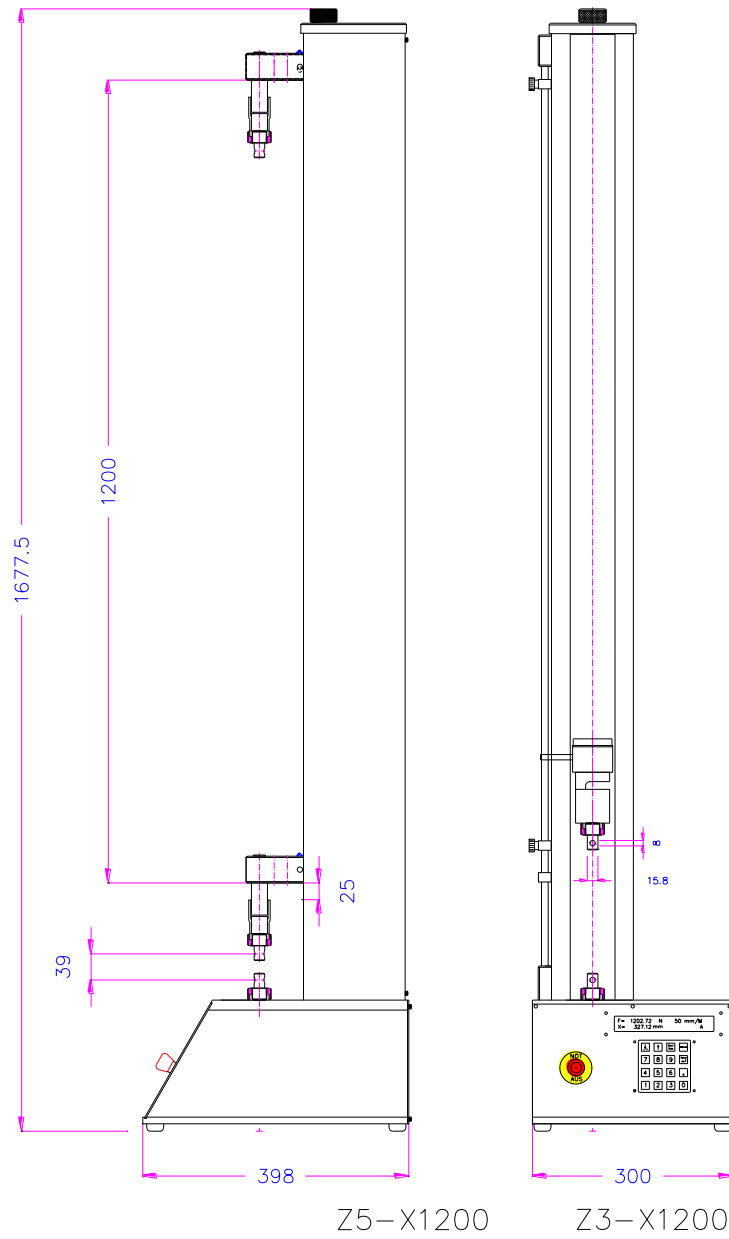

Z3-X1200

Z3-1200 Z5-1200

Z10-X700
 10kN
 700mm

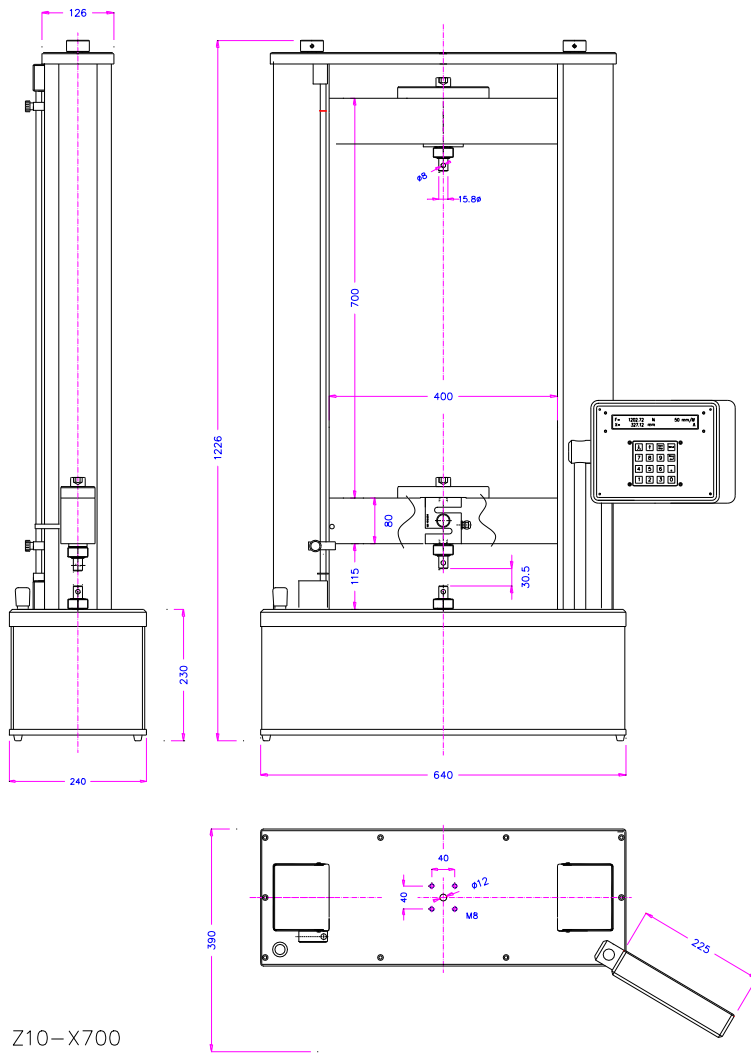

Z10-X700



Z10-X700-W600 inner width 600mm

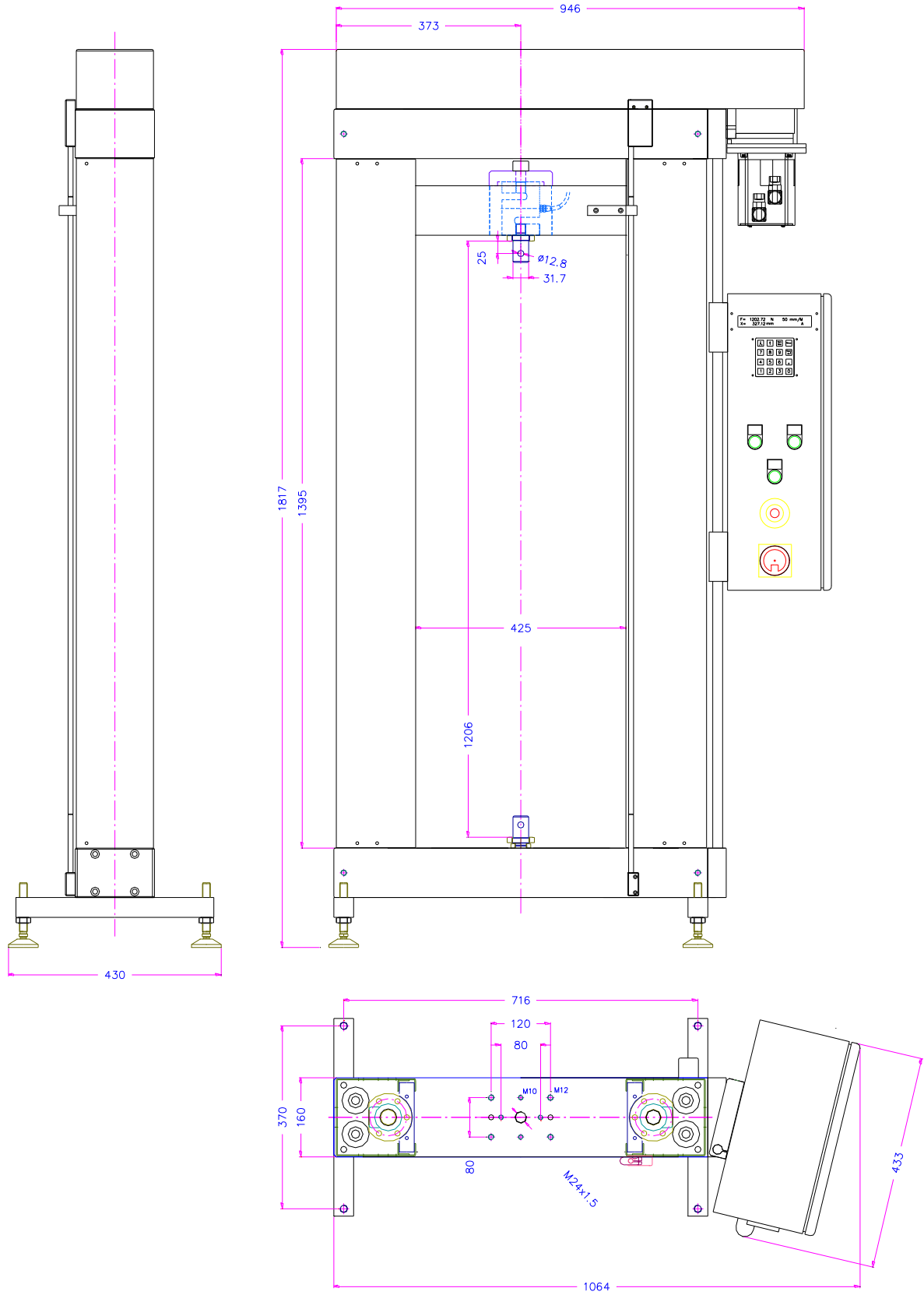



Z20 -1200 Z50-1200

15) Declaration of Conformity

Test - Certificate

Testing machine: Z3, Z5, Z10, Z20, Z50

Serial number:

customer:

The testing machine listed above meets the requirements of DIN 51 221st
It is capable of acceptance by class 1

The load cells are used for calibration are approved as certified equipment, which will
be reviewed by the LGA Nuremberg.

Load cell: Nr

Non-linearity: 0.03%

Hysteresis: 0.015%

Manufacturer Nordic NTT

The load cell is capable of acceptance.

24.1.2014

Unterschrift 

Hans Traut Str. 25
Tel.: 09122-78711

90455 Nürnberg
Fax: 09122-73127

Germany
info@grip.de

Declaration of Conformity

Name and

Location of producer: Thümler GmbH 90455 Nürnberg Hans Traut Str. 25

Name of machine small tensile tester Z3, Z5, Z10, Z20, Z50

Directives

Compiled with

European CE Health and Safety Directives
EN 50081-1, 580081-1, und EN 61010-1 und EWG 91/368, EWG 93/44
VDE 0100, VDE 0106, DIN 57113 / EN 60204, VDE 0160, VDE 0660
BVG A1, BVG A3
2006/95/ EG low Voltage Directive

2006/95/EG Voltage limits
2004/108/EG electromagnetic compatibility
DIN EN 61000-4-2; VDE 0847-4-2:2009-12:2009-12 EMV
DIN EN 61496-1; VDE 0113-201:2009-03:2009-03 safety of machines

Responsible M. Thümler Dipl. Ing. (Univ.) Maschinenbauing.

Function Line, development, conception, construction
registered into the following handicrafts registers
- Elektromechanikerhandwerk Lfd. Nr. 92/09/132 BNR 0052159
- Maschinenbauerhandwerk Lfd. Nr. 87/13/062 BNR 0052159

Nürnberg, den 24.12.2012



.....

Appendix

17.1 Determination of the force that generates a known weight in the gravitational field of the earth

$$F = G * g \text{ [Newton]}$$

G = weight in kg

G = acceleration due to gravity 9.81 m / sec

Dependent on location

*With the formula $9.780327 * (1 + 0.0053024 * \sin^2 (Y) - 0.0000058 * \sin^2 (2Y)) - 3,086 / 1000000 * \text{height}$ you can calculate the gravitational acceleration.*

Determining the amount and the latitude

- 1. Open the Internet <http://gps0.de/maps/>*
- 2. In the blue field enter the address of the site and click OK*
- 3. In the right red box you can use the latitude in the form xx xx ° XX "*
- 4. And read the middle gray area the height in meters.*

Change Serial Number

1. change the serial number with command SER: xx.yyyy\$
 2. go to user menu, change one element i.e.: end pos = 101 mm, and on the end of menu save changes (key '1')
- your new serial number will be stored in Flash, to get it back, send SER?\$

P.S.

Turn lower Adapter 90 °

Open the front panel 10 screws M5
Loosen the central screw in the middle of the base plate M12 Imbus DIN912

Turn the Adapter 90 °

Retraction

If the limit switch has triggered, please drive away manually

Maunal for software see:

<https://docs.google.com/document/d/1UE1UJU8Z809NpPGm3g3ZnkROBAgt09EiNoSr50wRXek/edit>

MT 25.10.2019